

Instruction Manual

Model F300-1

PICTURE FRAMING

STUDIO JOINER

**LOGAN**[®]
GRAPHIC PRODUCTS, INC.
Tools for Art - Tools for Life
www.logangraphic.com

Description

The model F300-1 Studio Joiner has been designed to economically and precisely drive V-nails into moulding corners to securely join them together. Simple and easy to use, this complete system produces strong, tight corners for high quality professional results. Accepts mouldings up to 2¹/₂" (64mm).

Producing professional quality picture frames is now easier than ever.

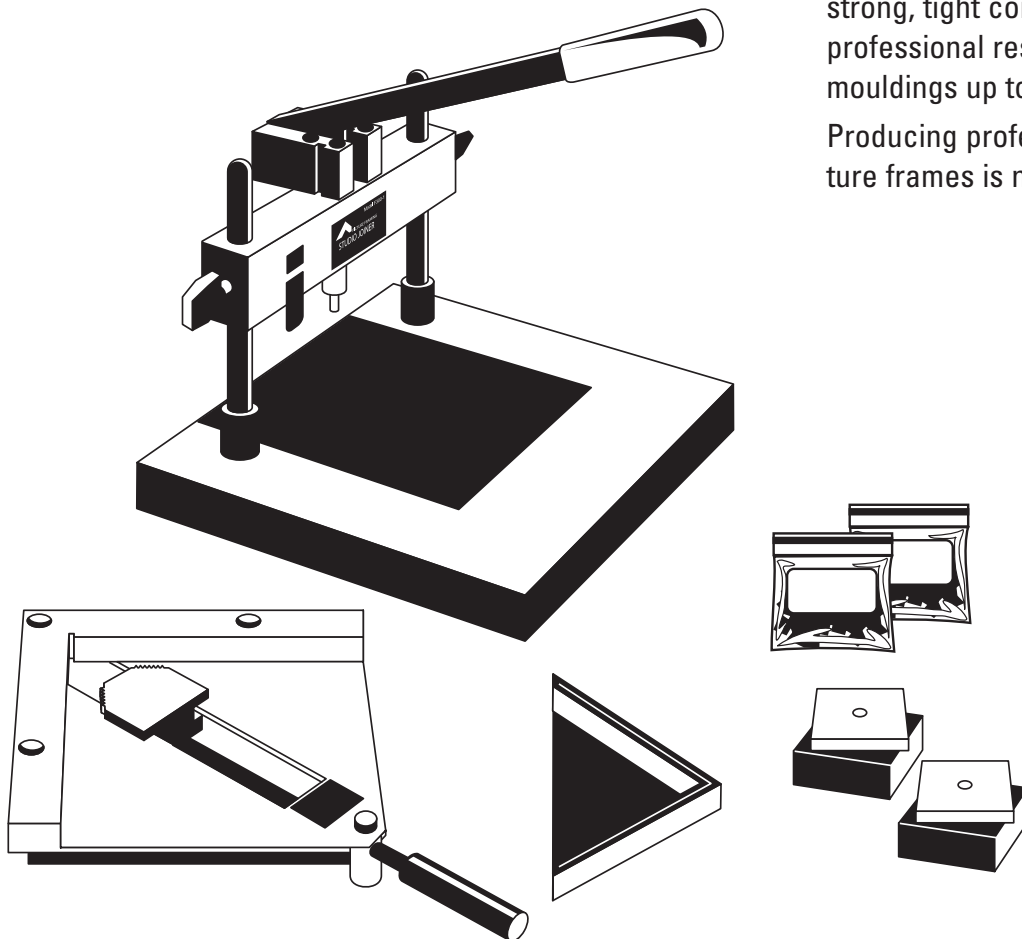

Reference Part No. L956N rev.1

Rev. 9/14

Identification

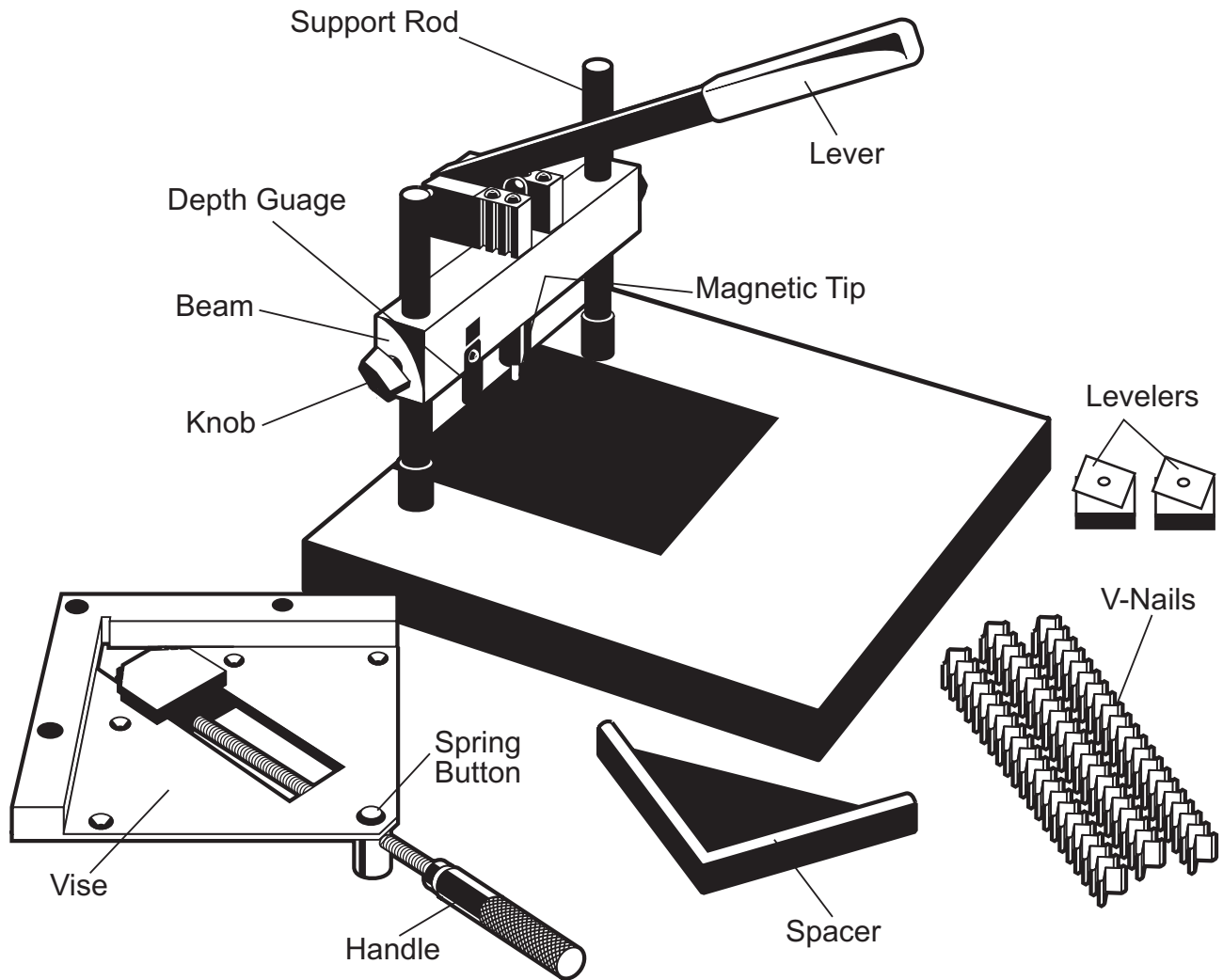

Beam - Adjustable cross bar which contains lever and V-nail driver.

Magnetic Tip - Spring loaded pin attached to V-nail driver which V-nails set on.

Depth Gauge - Indicator connected to beam which adjusts beam to proper height for driving V-nail.

Knobs- allow beam to be moveable for adjustment.

Support Rods - Rods which set into base board and provide support for beam.

Vise - Used to secure moulding for corner joining.

Handle - Used to tighten or loosen clamp jaw.

Spring Button - Press down and slide handle to quick adjust clamp jaw into position.

Spacer - Used for irregular shape moulding to provide solid surface for joining.

V-Nails - V-shaped fasteners used to hold moulding corners together.

Levelers - Small blocks designed to stabilize lengths of moulding extending off the board to help with beam height adjustment.

Parts List

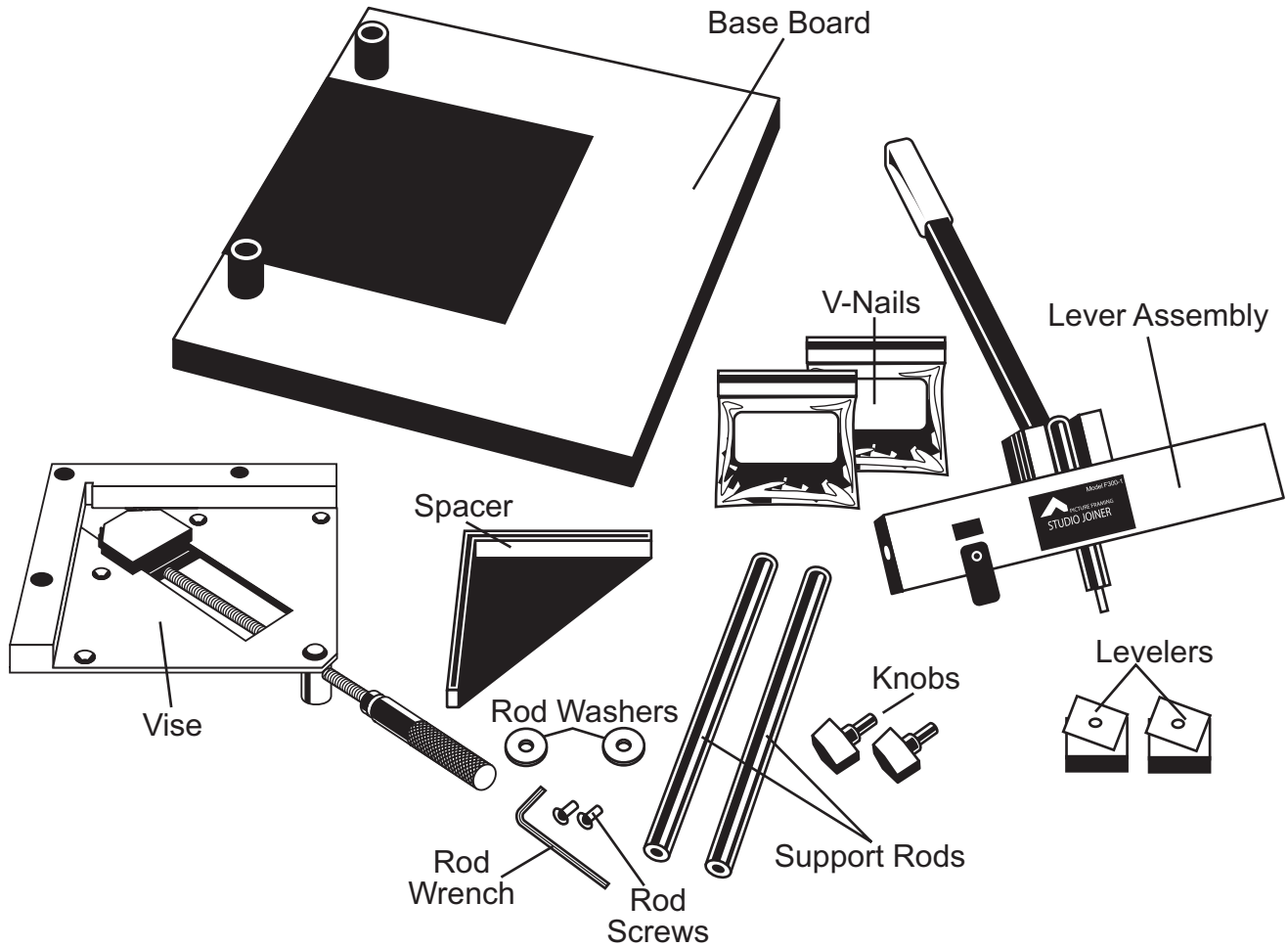

Parts List

Base board	1
Knobs	2
Levelers	2
Lever assembly	1
Rod Screws	2
Rod Washers	2
Spacer	1
Support rods	2
Visse	1
V-nails	200

Assembly Procedure

1. Slide support rods into sleeves in board (Fig. 1).
2. Attach support rods with rod screws and washers using rod wrench (Fig. 2).
3. Slide lever assembly over support rods (Fig. 3).
4. Screw knobs into lever assembly (Fig. 4).

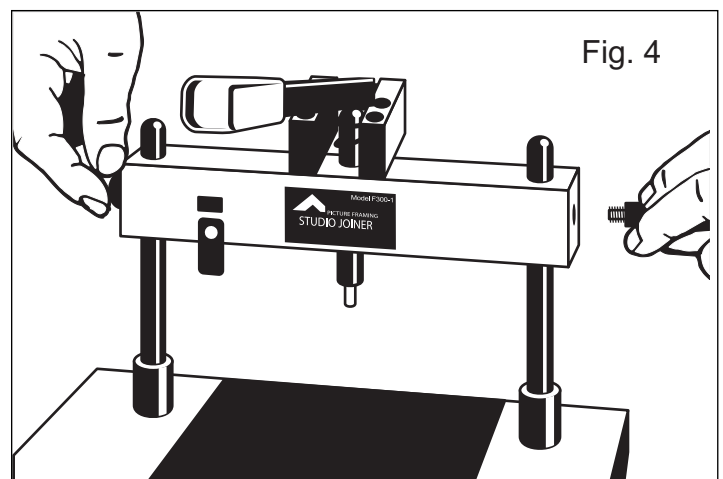
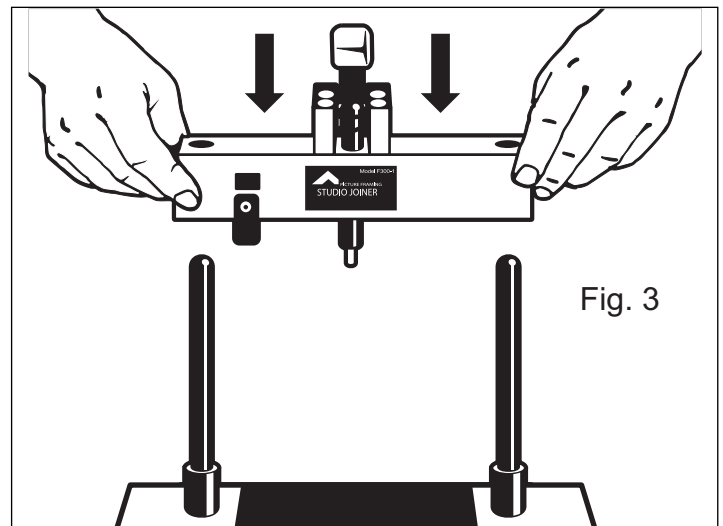
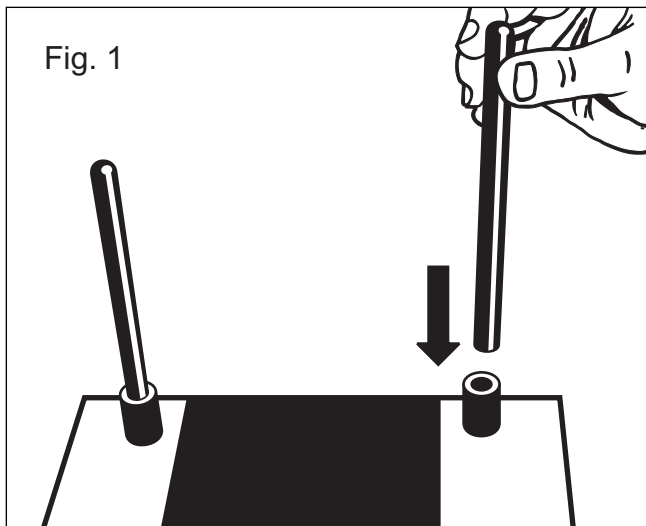
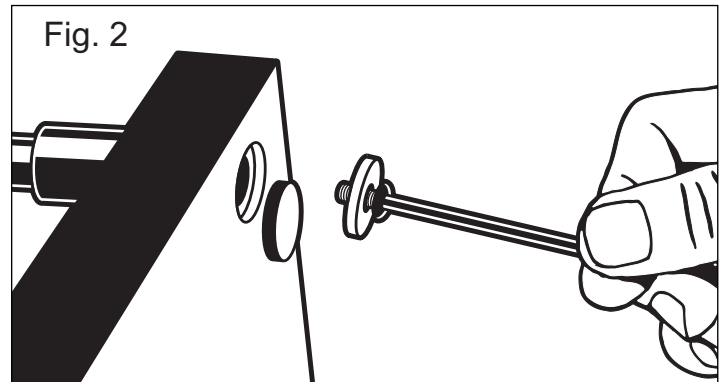

Preparation

A. Choose V-nail type, size and quality

1. V-nail Type
 - a. Hard Wood Nails - Used for very hard woods like oak and maple. Do not use on soft woods.
 - b. Soft Wood Nails - Used specifically for soft woods but can be used on hard woods.
2. V-nail Size
 - a. Choose a size nail that is at least 1/2 the moulding thickness.
3. Quality
 - a. Use at least two V-nails per joint.
 - 1/4" to 1 3/4" wide moulding - 2 nails
 - 2" to 2 1/2" wide moulding - 3 nails

For information on how to purchase additional V-nails see page 10.

B. Clamp Moulding



- Mark edge of miter to blend any gaps in corner (Fig. 5) using a stain marker. Stain markers can be purchased at a hardware store.



- Glue moulding miter for long lasting solid corners (Fig. 6).

1. Adjust clamp jaw by pressing spring button and sliding handle (Fig. 7).
2. Align moulding pieces in vise so top corner is square (Fig. 8).
3. Do not overtighten. The moulding only requires enough clamping pressure to hold it still (Fig. 9).

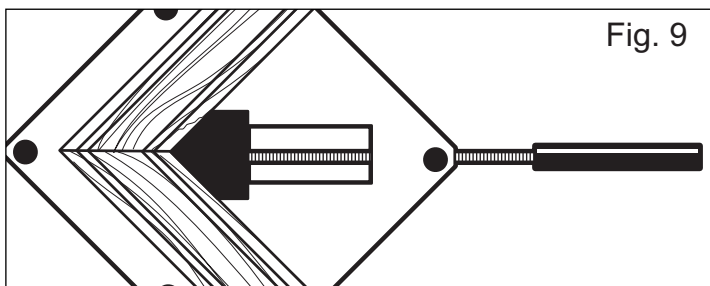
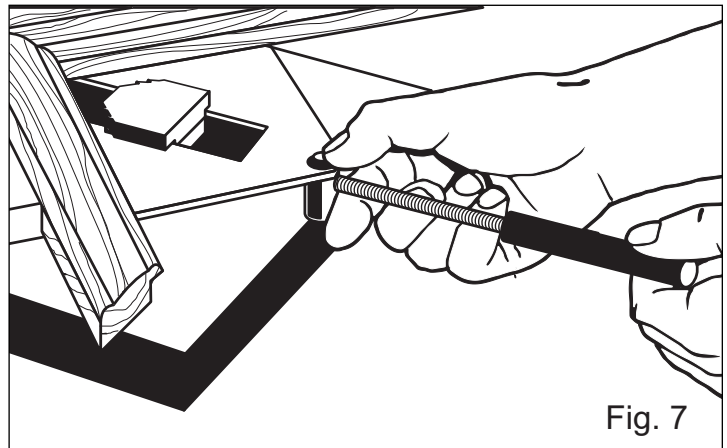
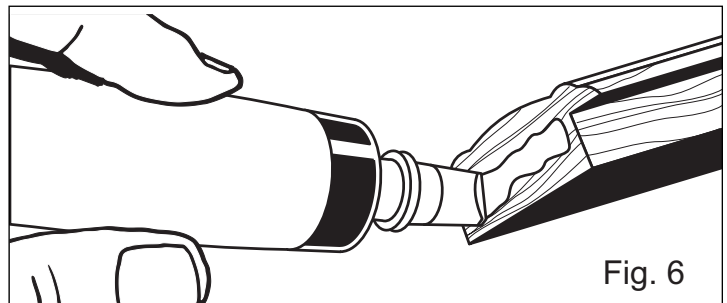
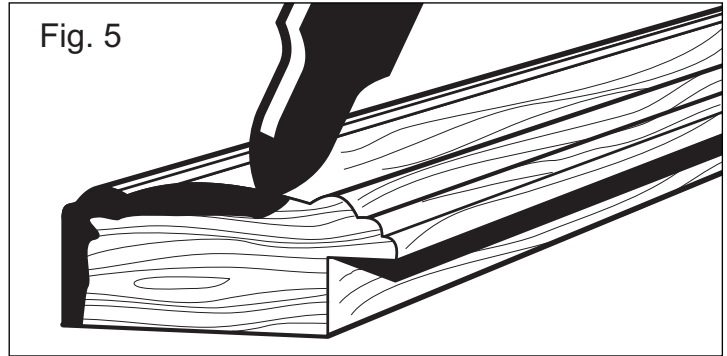

Preparation continued

C. Moulding Spacer

1. Moulding must have support for V-nail to drive into wood. Use the spacer when moulding is not even with horizontal plane (Fig. 10).
2. With rubber edges facing up, place spacer between clamped moulding and base board (Fig. 11).

D. Adjust Beam Height

1. Turn clamped moulding over and lay on base board spacer (Fig. 12). If using spacer, position clamped moulding on spacer where V-nail is to be pressed in.
2. Line up depth gauge with vise post.
3. Loosen knobs and adjust beam so depth gauge lightly touches vise post (Fig. 13).
4. Tighten knobs.
5. The depth gauge may be pivoted either to left or right to gain extra clearance.

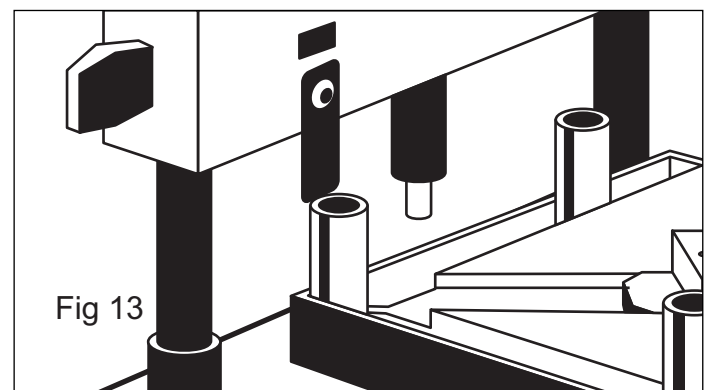
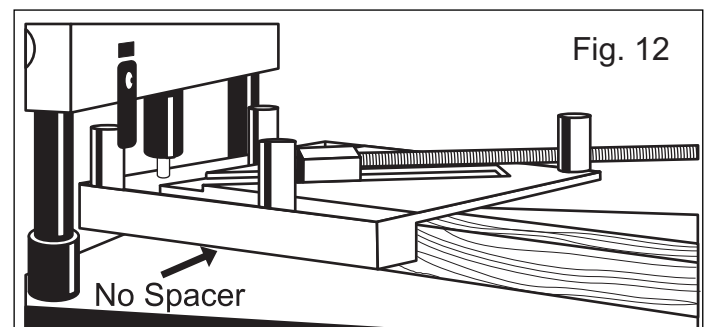
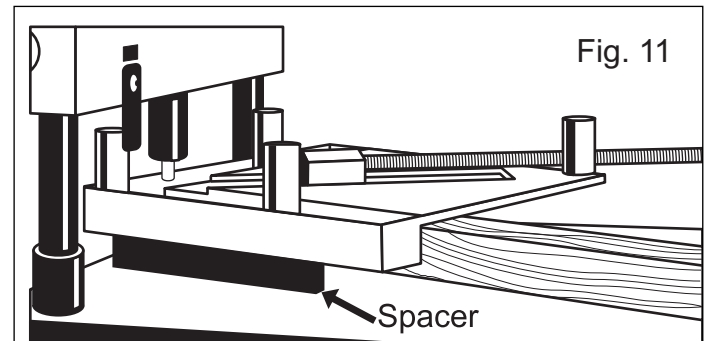
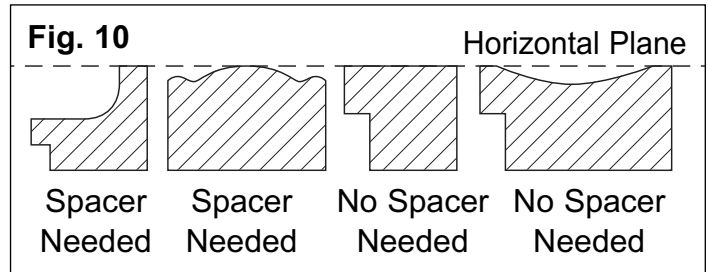

Operation

A. Load V-Nail

1. Align V-nail around magnetic tip with beveled sharp edge of nail facing down (Fig. 14).

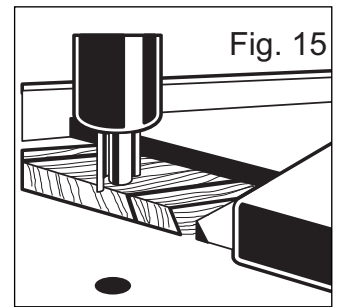
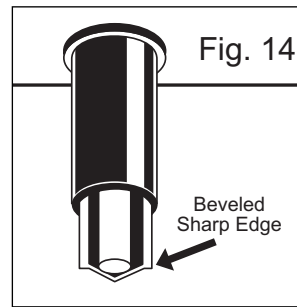

B. Press V-Nail

1. Press V-nail into inside corner first. Slide vise corner under magnetic tip and V-nail (Fig. 15).
2. Space V-nail 1/4" from inside corner (Fig. 16).
3. Press V-nail flush using lever (Fig. 17).
4. Load second V-nail.
5. Slide vise locating V-nail 1/2 distance between first V-nail and outer corner (Fig. 16).
6. Press V-nail flush using lever.
7. Repeat on other corners to complete.

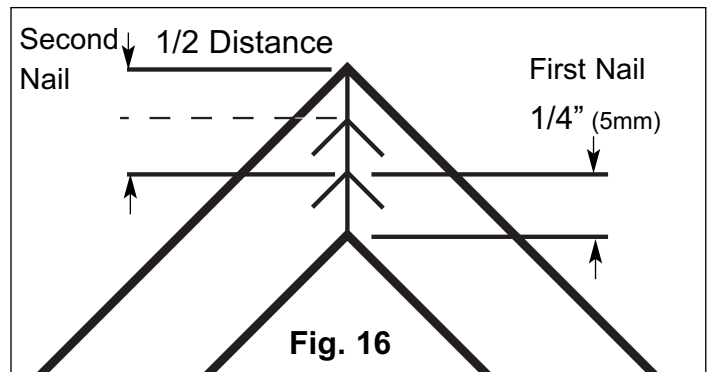

- Join sides of frames first. Then join halves to finish (Fig. 18).



- Always put longer length in vise on right hand side and shorter length on left hand side .

8. The Levelers can be deployed to help stabilize the moulding and or vise that extends past the edge of the board to allow proper setting of beam height (Fig. 19).

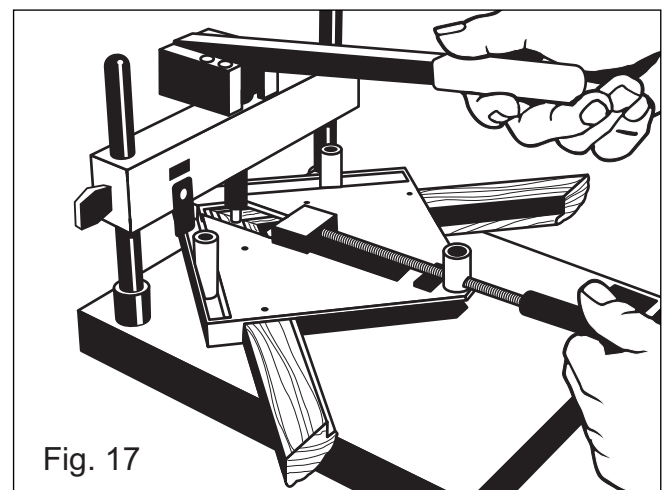

- The Studio Joiner can easily join polystyrene and Emafil plastic mouldings by slowly but firmly pressing V-nails in. Note; these will bend if pressed in too fast.

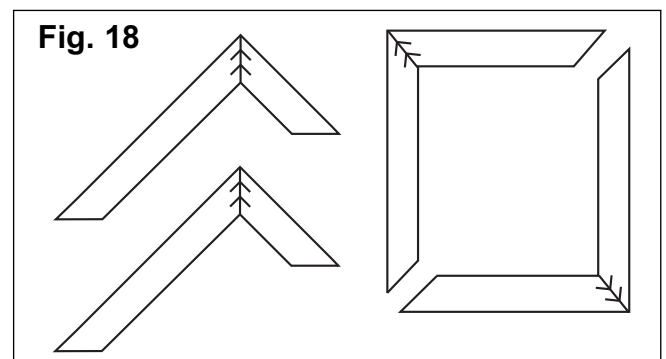
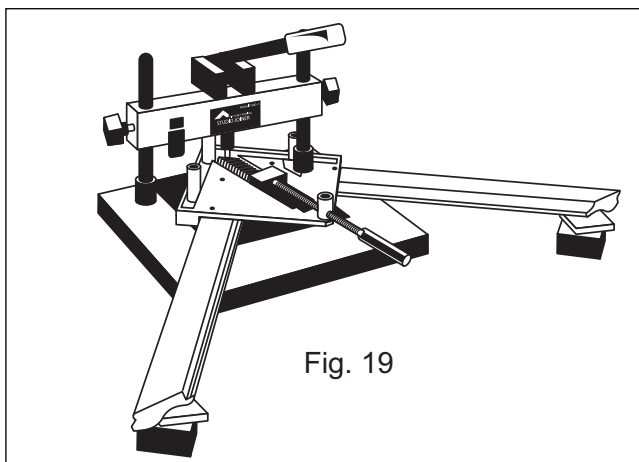

Operation Continued

C. To Join Multi Sided Frames

Note; The steps below apply to all five sided, six sided and eight sided frames.

1. Once the frame has been 'strap clamped' (not provided) the Beam must be removed.
2. The clamped frame may now be placed over one of the Post's (Fig. 20).
3. The Beam can now be replaced.
4. The Beam must have the correct height set by using the Vise that is currently not being used. Simply place the Vise upside down on the board and set height as described earlier in this manual (Fig. 21).
5. The V-Nails can now be pressed in, in the normal fashion (Fig. 22).
6. Once all the frame corners have at least two V-Nails, simply remove the Beam and remove the frame.

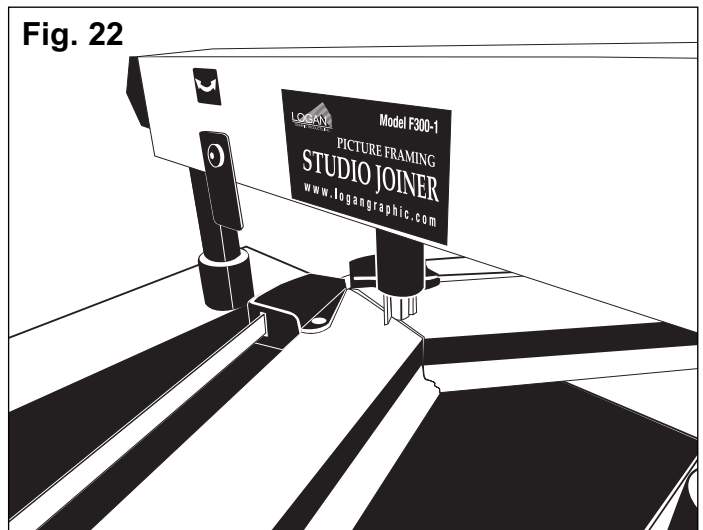
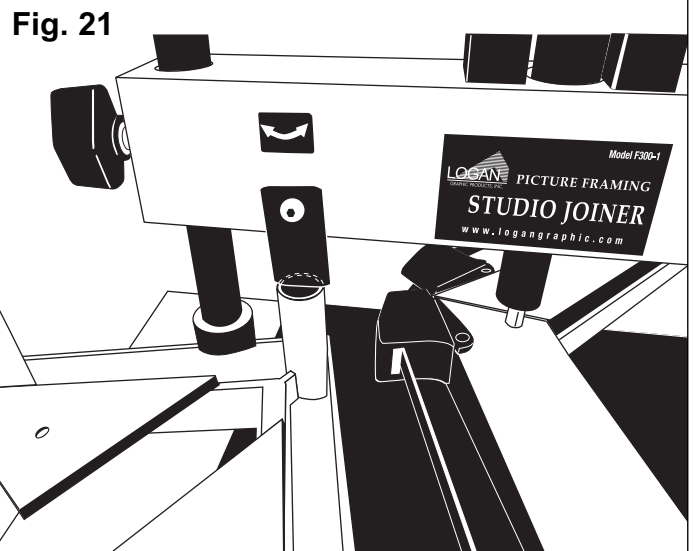
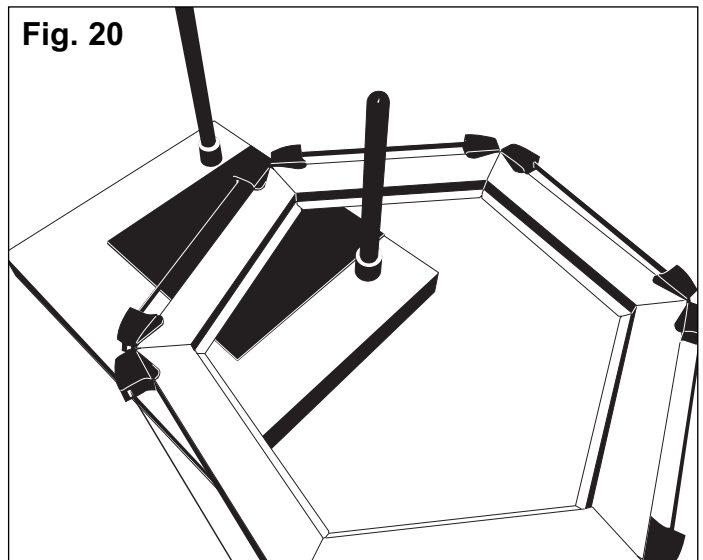

Trouble Shooting

Problem	Solution
V-nail is not driven in all the way.	Re-adjust depth setting. Refer to instructions. Use correct size V-nail.
Joint opens up when driving V-nail in.	Use the spacer provided and position under where the V-nail is to be driven in. Make sure the moulding is securely clamped in vise, and is square against the fence back.
Magnetic V-nail holder sticks in the shaft after insertion of V-nail.	Remove Beam to gain better access to magnetic V-nail holder and clean using solvent to remove glue residue. Use less glue and have damp cloth on hand to clean up any squeeze out that occurs.
Frame does not assemble correctly.	Join sides of frame first, then join halves to finish. Always put longer length in vise on right hand side and shorter length on left hand side.
Gaps in joints.	Sand Miters smooth. Make sure the two pairs are equal length. Reduce the amount of glue in joint. Check square cutting action of saw. Use longer V-nails if possible.
Clamped moulding does not fit in between posts.	Lift Beam off of support rods, and place vise with moulding in between support rods and then re-set beam height, to continue to press V-nail's in.

Warranty

Logan Graphic Products, Inc. ("Logan") warrants the Studio Joiner - Model F300-1, to be free from defects in parts and workmanship for a period of one year from the date of original purchase. Logan warrants that it will either repair or replace, at it's sole discretion, any necessary replacement parts found to be defective. Should the product need to be returned to Logan for repair or replacement parts, authorization for any return must come from Logan in writing.

Costs of returning the product to Logan, including insurances, shall be borne by the purchaser. Logan shall not be liable for any damages or losses, incidental or consequential, direct or indirect, arising from the use of this product. This warranty extends only to the original purchaser and is not assignable or transferable. This warranty is in lieu of all other warranties, expressed or implied.

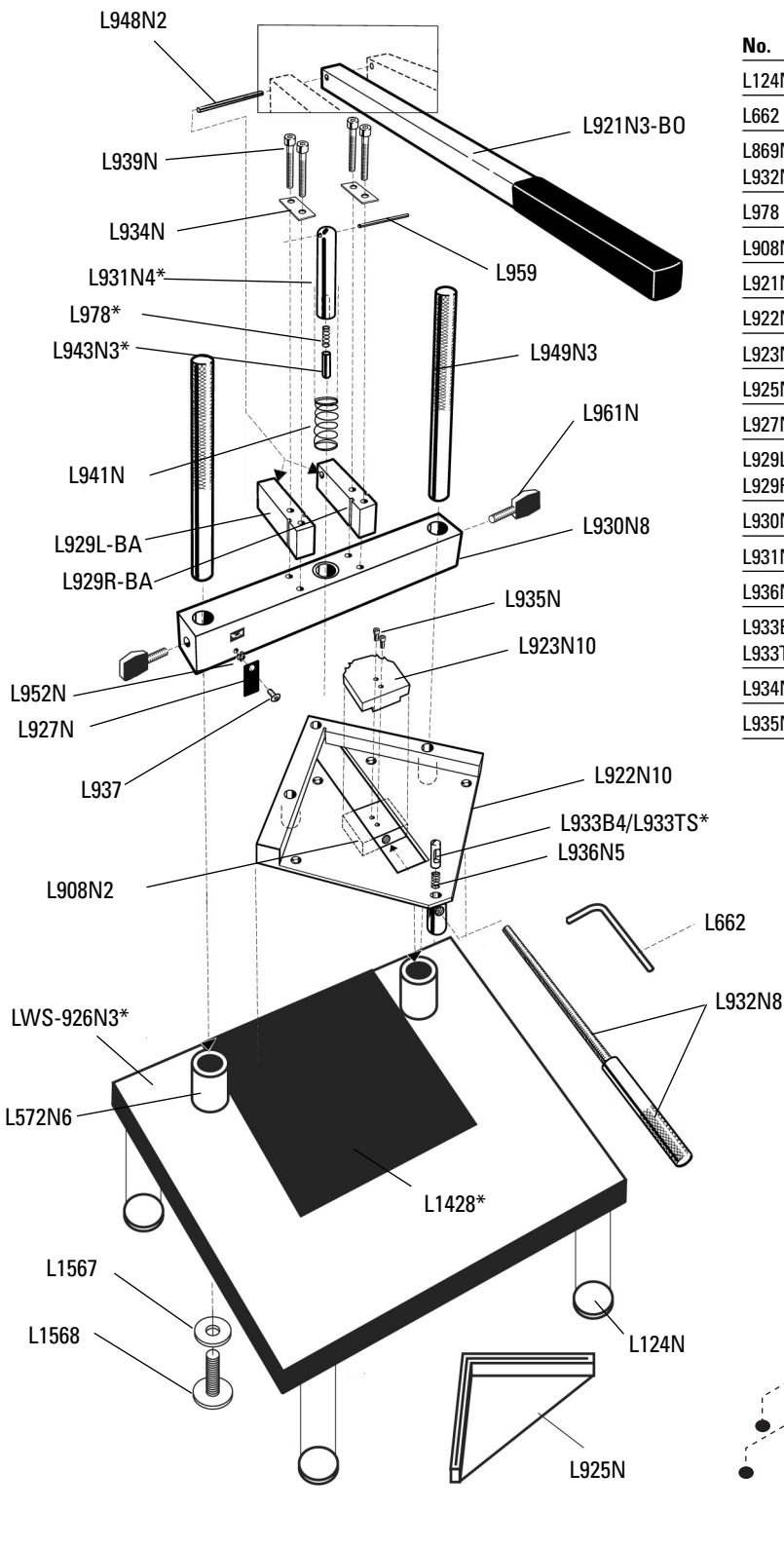

No.	Description	Qty.
L124N	Feet	5
L662	Wrench	1
L869N/ L932N5	Clamp Screw	1
L978	Pin Spring	1
L908N2	Clamp Plate	1
L921N3-B0	Handle	1
L922N10	Clamp Base	1
L923N10	Clamp Jaw	1
L925N	Plastic Spacer	1
L927N	Depth Gauge	1
L929L-BA/ L929R-BA	Lever Block	2
L930N8	Beam	1
L931N4	Drive Rod	1
L936N5	Button Spring	1
L933B4/ L933TS	Spring Button	1
L934N	Block Cover	2
L935N	Jaw Screw	2

L937	Depth Gauge Screw	1
L939N	Block Screw	4
L941N2	Drive Spring	1
L943N3	Magnet	1
L948N2	Handle Pin	1
L949N3	Support Rod	2
L952N	Wavy washer	1
L959	Rod Pin	1
L961N	T-Knob	2
L1402N-CA	Leveler Top	2
L1403	Leveler Rod	2
L1428	Neoprene Pad	1
L1470	Leveler Feet	8
L1471	Leveler Base	2
L1472	Leveler Threaded Sleeve	2
L1567	Washers	2
L1568	Screws	2
LWS-926N3	Base Board	1

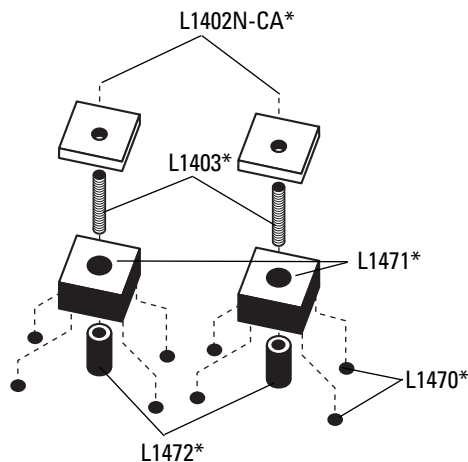

* Items are only available as preassembled parts.

ALSO AVAILABLE FROM LOGAN GRAPHICS

Logan Graphics Picture Framing System includes all the tools and accessories you need to produce professional quality frames including...

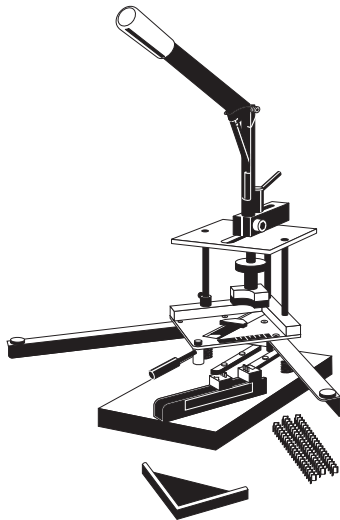

PRECISION SANDER ELITE

Model F200-2

Sands miters to perfect 45° angle for tight, square frames

- 10 lb wheel
- Adjusts 45° left, 90° and 45° right
- Micro adjustment for perfect 45°
- Aluminum oxide sand paper with life extending bar
- Sand up to 2 1/2" (64mm) mouldings
- Dust removal bar

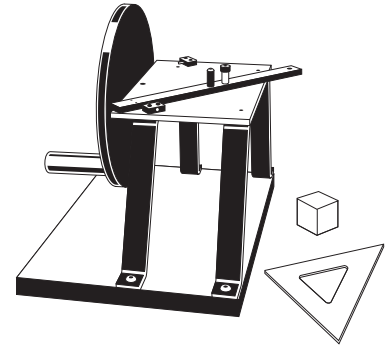

PRO JOINER Model F300-2

Heavy duty professional-style joiner for precise corner joints

- V-nail alignment pins*
- Drives all V-nail sizes
- Fits mouldings up to 2 1/2" (64mm)
- Can drive two nails at once

*Patent Pending



REPLACEMENT V-NAILS

Find replacement V-nails where you purchased your tool.

- 1/4" (7mm), 3/8" (10mm) and 1/2" (12mm) sizes are available for both soft and hard wood applications, packaged in quantities of 200.

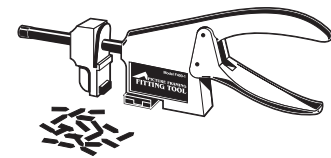

FITTING TOOL Model F400-1

Drives brads or point inserts into wood frames to hold materials in place

- Drives four different inserts
- No slipping or bending
- Removes inserts
- Easy adjust foot
- Use on hard or soft woods
- Patented rotating insert holder
- Proper drive angle assured
- No guessing or skill required

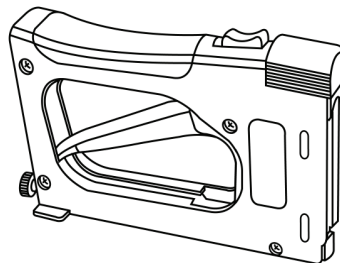

DUAL DRIVE ELITE

Model F500-2

Spring-loaded action drives both rigid and flexible points to secure artwork in both hard and softwood frames

- Holds stacks of flexible or rigid points for fast productive framing
- Comfortable handle grip and smooth firing action
- Must-have for artists, framers and hobbyists!
- For best results, using only authentic Logan points

For more information, including where to buy Logan Framing Products, Please visit us at www.logangraphic.com or call Toll Free (800) 331 6232.