

Identification

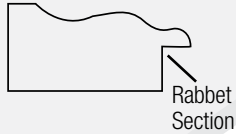

Rabbet Section

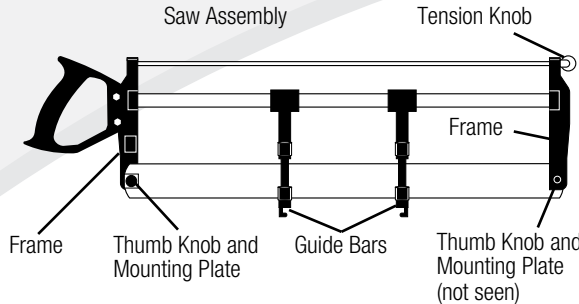

Description

The Pro Saw Model F100-2 is a complete framing saw system which will produce precise 45° miters for picture frame corners. Features include measuring scales, fence stop, adjustable angle setting, two moulding clamps and a specially designed saw for close tolerance cutting. Producing quality picture frames is easier now than ever. The Pro Saw Model F100-2 has undergone some recent design and feature updates. While usage instructions remain essentially the same, you may notice that your saw differs slightly in appearance from the saw shown in the instruction manual, as well as on the enclosed DVD.

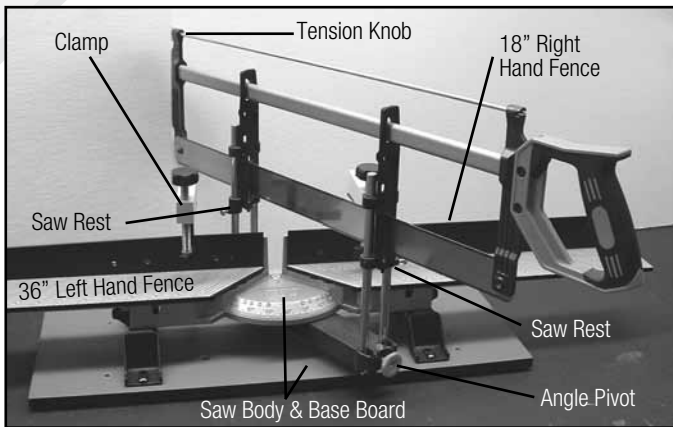

Angle Pivot - Adjustment arm holds saw assembly. Rotate to various angle settings from 45° to 90° to 45°.

Clamp - Quick slide moulding clamp used to keep moulding secure for cutting.

Clamp Rods - Clamp support rods.

Fence and Scale - 36" to left section and 18" right section. Scale is specially designed for measuring 45° picture frame miters.

Saw Rests - Device holds up saw so moulding can be maneuvered on fence.

Leg - Support for 36" fence section.

Rabbet - Undercut of moulding which holds frame material.

Saw Assembly - Saw blade is 24 tooth/inch for precise cutting. Knob allows simple blade change.

Saw Body and Base Board - Main platform of saw.

Saw Stop - Allows moulding to be cut in identical lengths.

Tension Knob - For keeping blade stiff.

Thumb Knob and Mounting Plate - Holding blade to frame.

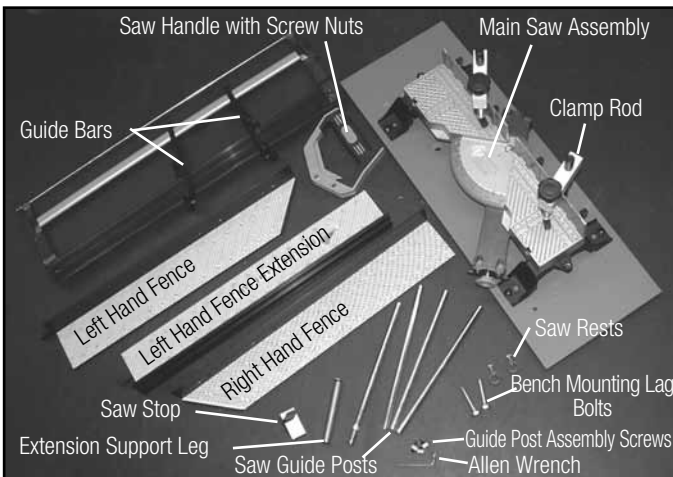

Parts List

18" Fence Extension	1
18" Left Hand Fence	1
18" Right Hand Fence	1
Allen Wrench	1
Bench Mounting Lag Bolts	2
Fence Connector Screws	4
Saw Handle with Screw Nuts	1
Saw Guide Posts	4
Guide Post Assembly Screws	4
Extension Support Leg	1
Main Saw Assembly	1
Saw Rests	2
Saw Stop	1

Warranty

Logan Graphic Products, Inc. ("Logan") warrants the Pro Saw - Model F100-2, to be free from defects in parts and workmanship for a period of one year from the date of original purchase. Logan warrants that it will either repair or replace, at its sole discretion, any necessary replacement parts found to be defective. Should the product need to be returned to Logan for repair or replacement parts, authorization for any return must come from Logan in writing. Costs of returning the product to Logan, including insurances, shall be borne by the purchaser. Logan shall not be liable for any damages or losses, incidental or consequential, direct or indirect, arising from the use of this product. This warranty extends only to the original purchaser and is not assignable or transferable. This warranty is in lieu of all other warranties, expressed or implied. Be advised that any Logan products purchased as "new" from an unauthorized dealer, such as an online auction site or similar, may be void of their warranty.

Exploded Parts Diagram Available Online at LoganGraphic.com

Assembly Procedure

A. Fence

1. Tighten both rear thumb screws (Fig. 1 & 2).
2. Repeat steps 1 and 2 for left hand fence.
3. To attach extension fence, feed the fence section into connectors extending from one another (Fig. 3).
4. Tighten connectors with thumb screws (Fig. 4).
5. To attach leg, turn saw base on it's side.
6. Loosen screw on support leg, then slide leg with screw tab attached into channel of fence extension to the desired position (Fig. 5).
7. Tighten leg by turning leg until secure.

B. Stop

1. Slide moulding stop onto fence (Fig. 6).
2. Tighten knob to lock.



Mounting-Optional

Mount base board to table using mounting screws supplied. Drill 1/4" (6mm) pilot holes for bolts.

C. Handle

1. Be sure not to lose the two nuts.
2. Slide handle onto end of saw and line up the bolt holes (Fig. 7).
3. Using Allen Wrench, tighten screws to secure handle (Fig. 8).

D. Saw

1. To insert the four saw guide posts into the saw assembly:
 - a. Place the four saw guide posts into position on the angle pivot.
 - b. Insert the guide post assembly screws with the screwhead facing outward in the slot in front of each saw guide post.
 - c. Using the Allen wrench, tighten the screw heads (Fig. 9).
2. To install the saw rests, slide one each onto both the front right and back left guide posts (Fig. 10).
3. Slide saw onto rods with handle onto same side as angle pivot handle (Fig. 11).

E. Blade Changing

1. Loosen tension knob but do not totally remove (Fig. 12).
2. Slide blade free of guide bars.
3. Reverse steps 1-3 for replacing with new blade.
Note: Be sure blade teeth are angled pointing away from handle.

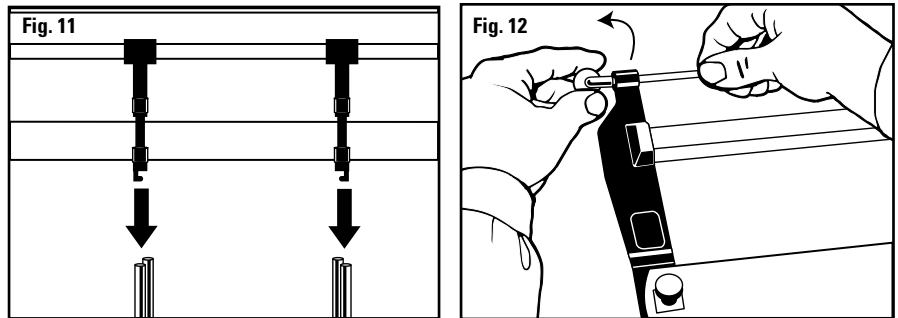
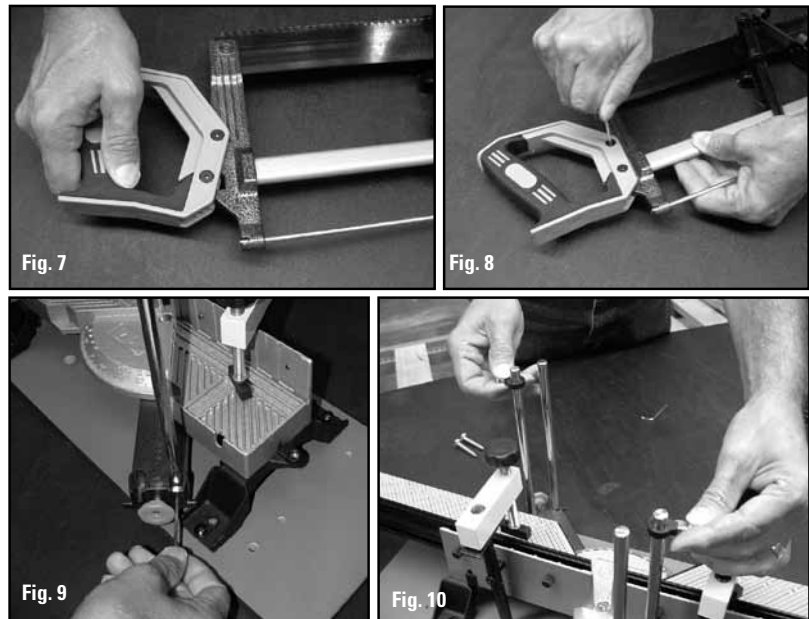
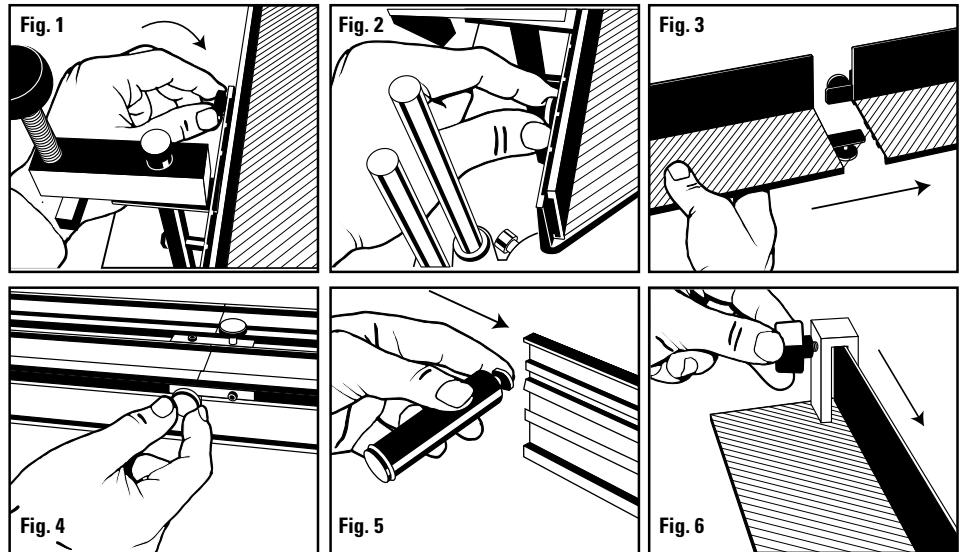

Saw rests explained - The **saw rests** are an added feature to raise the saw out of the way while the moulding is being positioned. To use the rests, first raise the saw upward on the guideposts. Next, slide the saw rests upward on the guidepost into position and tighten the screw.

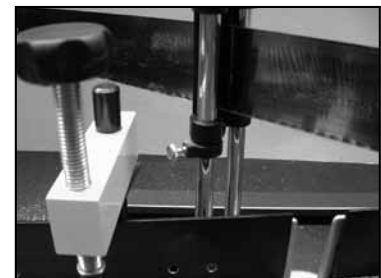

Preparation

A. Calculate Amount of Moulding Needed

1. Inside length and outside length differ because of 45° miter.
To calculate actual length needed (outside length) use this formula:
Outside length = (inside length) + (2 x moulding width) + (1/8" clearance)
Clearance: Allows frame material room to fit into frame.

EXAMPLE:

Inside dimensions = 16" x 20"
Moulding width = 1-1/2"
Outside Lengths = $16" + (2 \times 1-1/2") + 1/8" = 16" + 3" + 1/8" = 19-1/8"$
 $20" + (2 \times 1-1/2") + 1/8" = 23-1/8"$
So... 2 pieces x 19-1/8" = 38-1/4"
2 pieces x 23-1/8" = 46-1/4"
TOTAL 84-1/2"

NEEDED:

Either 2 pieces 19-1/8" and 2 pieces 23-1/8" or
1 piece 38-1/4" and 1 piece 46-1/4" or 1 piece 84-1/2"

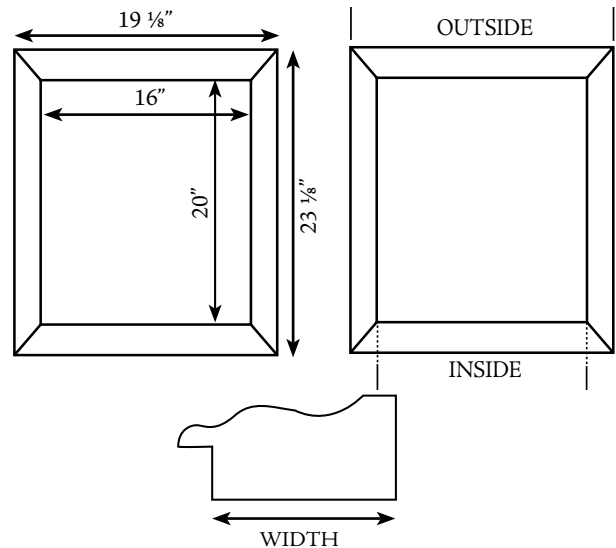

Operation

A. First Cut

1. Set angle pivot to 45° on right side by pressing pivot button and rotating angle pivot until angle block arrow lines up with 45° (Fig. 20 and Fig. 21).
2. Place moulding against fence finished side up and rabbet facing operator.
3. Slide moulding under saw blade far enough so full 45° cut can be made.
4. Change clamp height by adjusting block or screw so foot is over center of moulding (Fig. 22). To adjust clamp, squeeze lock plate and slide (Fig. 23). To adjust foot, turn knob.
5. Cut moulding (Fig. 24).

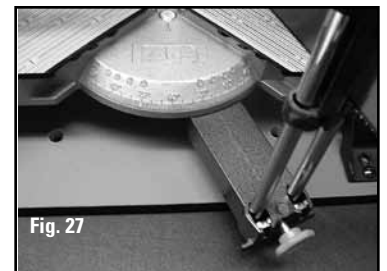
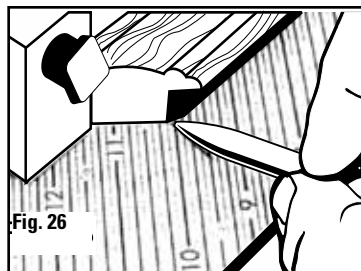
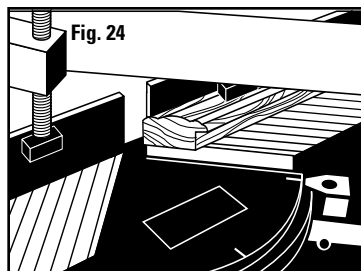
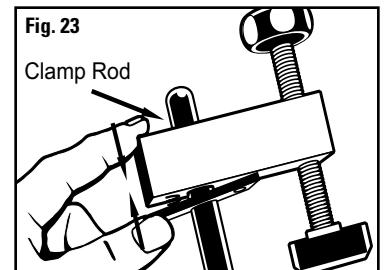
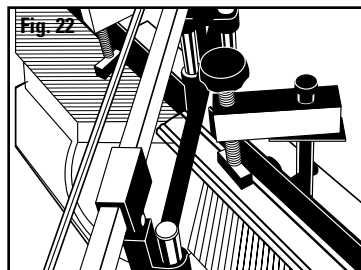
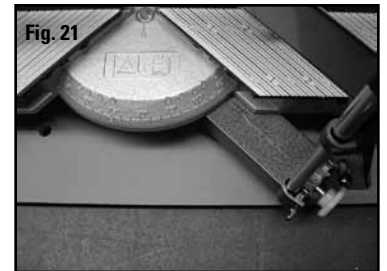
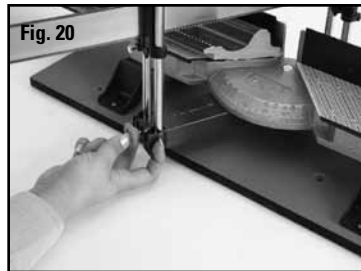

- Set foot parallel to moulding and as close to saw blade as possible.
- By making long full strokes, accuracy is improved and cutting is easier.
- Always cut long pieces first. If mistake is made, shorter pieces can be salvaged.

B. Second Cut

1. Set pivot to 45° on left (Fig. 25).
2. Slide cut end of moulding to desired dimension and align rabbet corner on scale dimension (Fig. 26).



- Always allow additional 1/8" for clearance.

3. Set stop against moulding.
4. Clamp both sides of moulding if possible.
5. Cut moulding.
6. Deburr bottom cut edge using sandpaper, sander or file.

C. Operation for Cutting Multi Angled Frames

1. Five positive stops are built into saw, allowing for accurate settings for multi-sided frames. Following are the pre-set stop settings:
 - 45 degrees = standard four sided frame
 - 54 degrees = five sided frame
 - 60 degrees = six sided frame
 - 67 1/2 degrees = eight sided frame
 - 75 degrees = twelve sided frame (Fig. 27)
2. Whatever type of frame is to be cut, you must set the saw swivel to the same degree setting on the left hand side to ensure that the frame will be cut correctly ready for sanding and joining. ***It may be easier to write numbers on the pieces in the order they are cut to ensure that they are joined in the right order and also to ensure you have cut enough pieces. The numbers could be on the underside of the moulding pieces.

Trouble Shooting • Problèmes et solutions • Solución de Fallas • Fehlerbehebung

ENG

Problem

Saw does not cut straight.

Solution

Increase blade tension using saw knob tension.
Tighten both pivot screws on back of saw base equally.
Tighten down on the angle block pointer, be sure you can still move the saw swivel from left hand 45° to the right hand 45° marks.
Make sure the moulding is securely clamped.

Problem

Difficult or slow cutting.

Solution

Make sure the saw blade is correctly installed (teeth facing away from handle).
Replace saw blade.

Problem

Clamp does not hold moulding securely.

Solution

Turn clamps 90° so that they press moulding into the base and back of fence.
Make sure the clamp posts are tight.

Problem

Moulding lengths are not consistent.

Solution

Make sure fence is secure.
Clamp left hand moulding first when using the stop.
Remove any saw dust, splinters and debris from between the moulding and fence and moulding and the stop.

FR

Problème

La scie ne coupe pas droit.

Solution

Augmenter la tension de la lame à l'aide du bouton de la scie.
Serrer uniformément les deux vis pivot au dos de l'embase de la scie.
Serrer le pointeur de bloc d'angle tout en s'assurant qu'il est toujours possible de pivoter la scie du repère de 45° côté gauche au repère de 45° côté droit.
Vérifier que la moulure est fermement serrée dans la presse.

Problème

Coupe laborieuse ou difficile.

Solution

Vérifier que la lame de scie est correctement installée (les dents tournées dans le sens opposé à la poignée).
Remplacer la lame de scie.

Problème

La presse ne maintient pas la moulure fermement en place.

Solution

Faire pivoter la presse à 90° de telle manière que la moulure s'appuie fermement contre la base et le dos du guide.
Vérifier que les montants de la presse sont bien serrés.

Problème

Les longueurs de moulure ne sont pas constantes.

Solution

S'assurer que le guide est bien fixé en place.
Placer la moulure du côté gauche en premier dans la presse si la butée est utilisée.
Nettoyer la sciure, les éclats de bois et les débris entre la moulure et le guide et entre la moulure et la butée.

ESP

Problema

La sierra no corta recto.

Solución

Aumente la tensión de la cuchilla usando la perilla de tensión de la sierra.
Apriete ambos tornillos del pivote en el dorso de la base de la sierra igualmente.
Apriete el indicador del bloque del ángulo, asegúrese que todavía se puede mover el eslabón giratorio de la sierra desde 45° a mano izquierda hasta las marcas de 45° de la mano derecha.
Asegúrese de que la moldura esté sujeta con la abrazadera con seguridad.

Problema

Corte difícil o lento.

Solución

Esté seguro de que la cuchilla de la sierra está instalada correctamente (los dientes mirando lejos de la manija).
Reemplace la cuchilla de la sierra.

Problema

La abrazadera no retiene a la moldura con seguridad.

Solución

Gire las abrazaderas 90° de modo que presionen la moldura en la base y el dorso de la cerca.
Esté seguro que los postes de la abrazadera estén apretados.

Problema

Las longitudes de la moldura no son constantes.

Solución

Asegúrese de que la guía está asegurada.
Sujete primero con la abrazadera la moldura de la mano izquierda al usar el tope.
Quite cualquier polvo, astillas y restos de sierra de entre la moldura y la guía y la moldura y el tope.

D

Problem

Säge schneidet nicht gerade.

Lösung

Erhöhen Sie die Sägeblattspannung am Knopf.
Ziehen Sie die Drehschrauben hinten an der Sägeunterfläche gleichmäßig fest.
Ziehen Sie am Eckversteifungszeiger fest, aber vergewissern Sie sich, dass Sie den Sägedrehpunkt immer noch zwischen 45° links und 45° rechts bewegen können.
Vergewissern Sie sich, dass die Zierleiste fest eingeklemmt wurde.

Problem

Schneiden ist schwierig oder langsam.

Lösung

Vergewissern Sie sich, dass das Sägeblatt richtig eingesetzt wurde (die Zacken müssen vom Griff wegzeigen).
Ersetzen Sie das Sägeblatt.

Problem

Klemme hält die Zierleiste nicht fest.

Lösung

Drehen Sie die Klemmen um 90 Grad, damit sie die Zierleiste in die Grundplatte drücken und von der Führung wegziehen.
Vergewissern Sie sich, dass sie Klemmstangen fest sind.

Problem

Zierleistenlängen sind nicht beständig.

Lösung

Vergewissern Sie sich, dass die Führung fest ist.
Klemmen Sie die linke Zierleiste zuerst, wenn Sie den Anschlag verwenden.
Entfernen Sie Sägespäne, Schmutz und Splitter aus den Zwischenräumen zwischen der Zierleiste und der Führung und der Zierleiste und dem Anschlag.

Also available From Logan Graphics

Logan Graphics picture framing system includes all the tools and accessories you need to produce professional quality frames including...